



"EAGLE" CAMPING TRAILER

OWNERS INSTRUCTION MANUAL



1 Move your Eagle to the desired camping spot. Release and position front loop legs to 7th notch.

TO RAISE TENT AT CAMPING SPOT



2 To position front legs release and push down to ground level. To adjust trailer body place foot on leg base lift up slightly on trailer body and bring leg lock pin to a notch or two higher leveling trailer. Remove travel cover.



3 Raise center tent bow and lock stay brace arms. Raise right top bow into position and lock stay brace arms. Pull right top bow out all the way to the stops.



4 Raise water tent bow into position and lock stay brace arms.



5 Release and lower bed support legs - adjust. (NOTE: Hold bed until one of the support legs is down, do not let bed drop.)



6 Raise left outer bow into position and lock stay brace arms. This will raise bed.



Vesely Manufacturing Co.

2101 NORTH LAPEER ROAD
LAPEER, MICHIGAN





Pull left bottom bed out all the way to the stops. Release and lower bed support legs - adjust.

TO RAISE TENT AT CAMPING SPOT

(continued)



Pull down canvas over bow system, attach to bed anchor clips and snap to trailer body.



Step inside and extend center telescope bow to desired height. Raise storage compartment.

For the Apache owners who have purchased the optional canopy with an **ADD-A-ROOM** or **SCREEN ENCLOSURE** the following instructions apply:
(ADD-A-ROOM shown)



TO STRIKE TENT FOR TRAVELING

Unhook elastic ties from bed anchor clips and body leg braces. Pull back corner stakes. Untie ties from outer canopy poles. Zip all windows, unstrap apron from trailer bed.

Unzip add-a-room or screen from canopy. Zip screen door.



Fold with screens in and roll up. It is recommended that the canopy be removed from the tent before striking.

Lower storage compartment to traveling position. Zip up all windows. Lower center telescope bow. Step outside and zip floor closed. Release tent from under beds and trailer body.



Fold canvas up over bow system. Raise left bed support legs and lock into travel position.

Push right bed in until it hits stops. Break center telescope bow stay braces and fold down. Neatly fold canvas on top.



1 Tie rope from loop on peak of tent to trailer coupler - zip canopy to tent.



2 Assemble two piece center canopy pole and stake out.



3 Stake out the two outer canopy poles.

Zip add-a-room or screen to face of tent and to save of canopy.



Spread out add-a-room or screen under canopy with screen door lined up with center canopy pole.

Secure grommet tabs under canopy poles.



6 Snap apron to trailer body. Hook elastic ties to bed anchor clips and to body leg braces. Stake out back corners.



3 Push left bed in until it hits stops. Break bow stay braces folding bow down lowering left bed into storage position.

Raise right bed support legs and lock into upright position.



4 Break bow stay braces, lower bow raising right bed.



6 Replace road cover. Release rear body leveling legs by lifting up on body and holding leg lock pin away from notches. Still holding pin pull leg up and lock in place. Front legs can be locked in place by lifting the tongue and releasing the leg pin pulling the leg up to the traveling position. Hitch trailer to car and a HAPPY SAFE JOURNEY HOME!

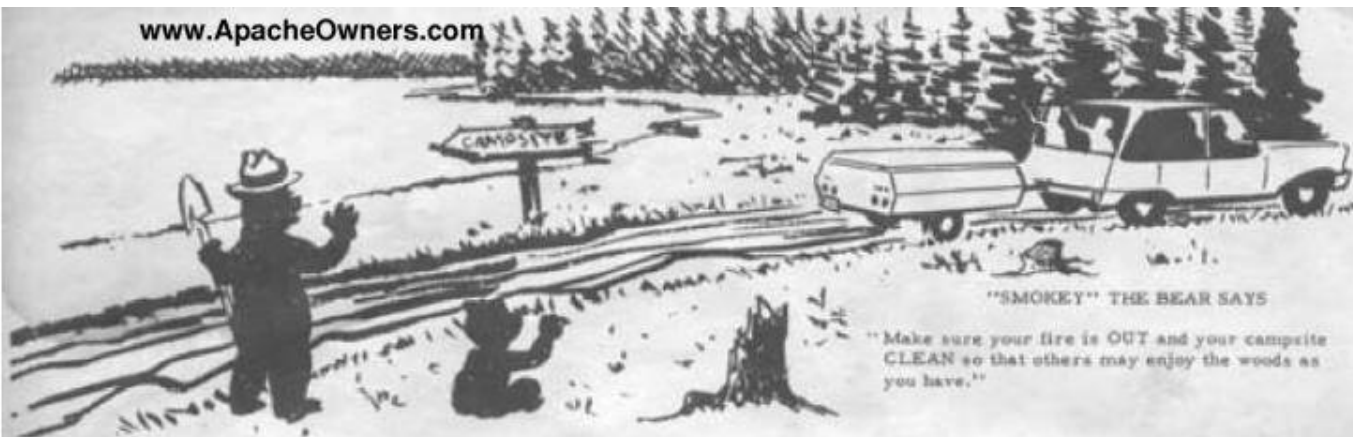

"SMOKEY" THE BEAR SAYS

"Make sure your fire is OUT and your campsite CLEAN so that others may enjoy the woods as you have."

A FEW SUGGESTIONS TO ASSURE YOURSELF OF CAREFREE TRIPS FOR YEARS TO COME.

CANVAS

The tent portion of your unit is one of the finest materials of it's type available. 13 oz. ceilings with 11 oz. side walls Vivatex treated. With proper care it will not require any further treatment for years to come. If any areas in the tent require retreating because of a mishap, we recommend Sail-Craft spray.

Adjustments are provided on telescope bows and guy ropes to relieve excess tension during wet weather. As with all canvas shelters it is recommended that the tent be soaked several times to close seams prior to first camping trip.

BODY

Tent may be struck for daily traveling when wet but should be dried and aired thoroughly before storing.

Any gear carried on bed should be packed UNDER folded tent.

Lock door before putting trailer on the road.

Waxing will help prolong the lustre of the body and act as a buffer to road salts.

Heavy items that have few points of contact with the bottom of the box should be padded and light gear packed around to prevent sliding.

Use powdered graphite occasionally as lock lubricant.

When packing compartments try to apportion weight equally. At hitch level the tongue weight of a properly loaded trailer will be about that of a beverage case - 40 lbs.

Record key number on registration in case of loss.

RUNNING GEAR

Proper inflation will prevent overheating and prolong tire life. A pressure of 45 lbs. is recommended when trailer is empty and 60 lbs. when trailer is loaded. (300 lb. payload.)

The Goodyear Tire Co. warranties your Apache tires - should adjustment be necessary take your tire to your nearest Goodyear dealer.

Repack wheel bearings every 2000 or 3000 miles. Be sure wheel spins freely after packing.

Check tongue, spring assembly, U bolts and wheel bolts before putting unit in service.

If replacement parts are needed, they may be ordered through your Apache Dealer.

Happy Apache Camping!

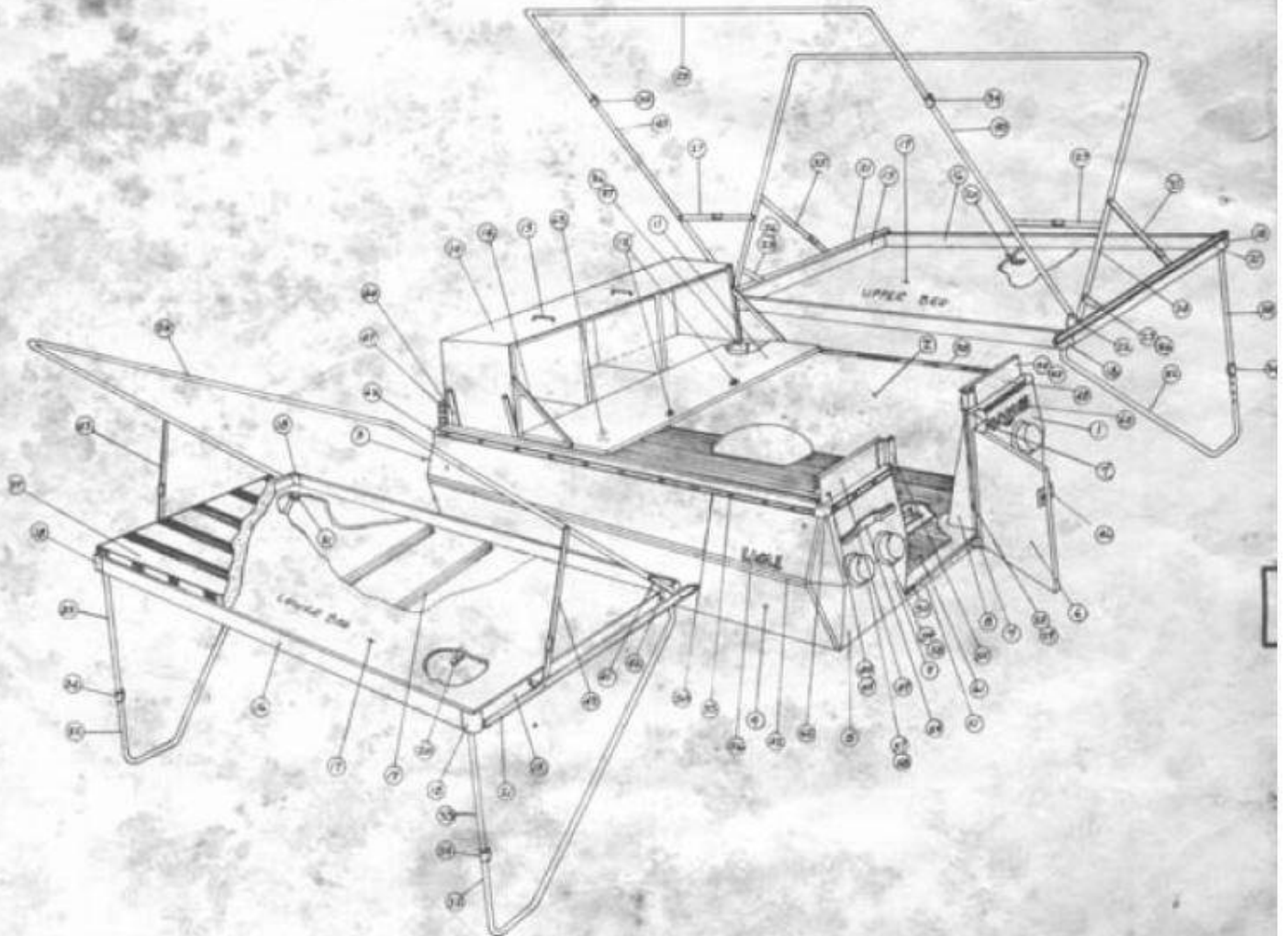
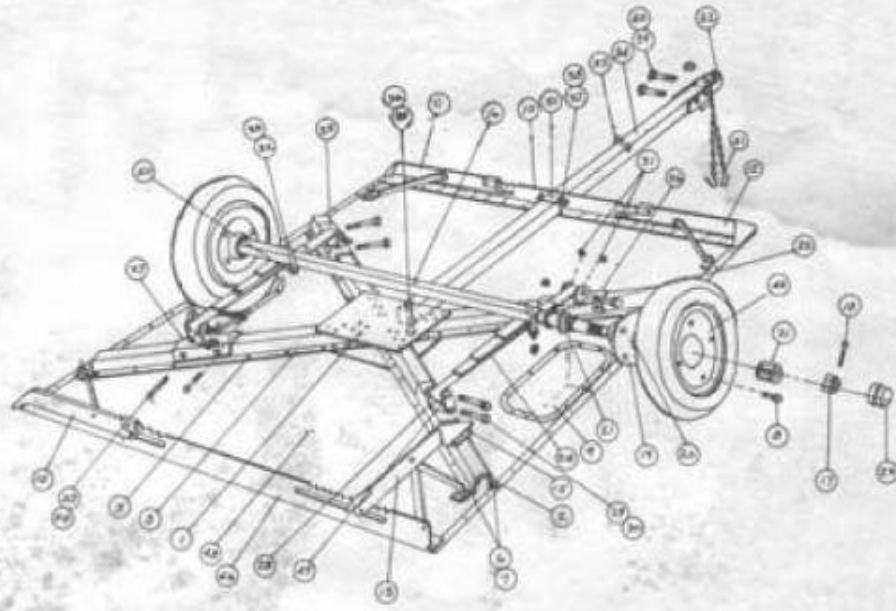

PARTS LIST

APACHE EAGLE CAMPING TRAILER

Item	Part No.	Req.	Description	Item	Part No.	Req.	Description
1	MB3-317	2	X Fr. Cent. Sup. Plate	30	PUN0-17R	6	Shackle Bolt Nuts
2	MB3-329	2	Short Hat Section	31	PUN0-24	12	Rub. Shackle Bushings
3	MB3-310	1	Long Hat Section	32	PJ3-351	2	U Bolts
4	SB3-316	1	Comp. X Fr. Assembled	33	PUN0-17R	4	U Bolt Nuts
5	FB3-460	56	X Frame Screws	34	MB3-358	1	Tongue
6	FB3-345	8	X Frame Bolts	35	PJ3-284	1	Tongue Bolt
7	FEBO2-181	8	X Frame Nuts	36	PJ3-289	1	Tongue Bolt Nut
8	PUN0-9	8	Leg Bolts	37	PJ3-284	2	Tongue Clamp Bolt
9	MEBO2-93	2	Wheel Well	38	PJ3-289	2	Tongue Clamp Nut
10	MB3-302	1	Front Reinf. Angle	39	PUN0-28	2	Trailer Coupler Bolt
11	MB3-282	1	Rt. Fr. Lev. Leg Assy	40	PUN0-29	2	Trailer Coupler Nut
12	MB3-288	1	Lt. Fr. Lev. Leg Assy	41	PJ3-374	2	Safety Chain & Hooks
13	MB3-282	1	Lt. R. Lev. Leg Assy	42	FB3-359	1	Spare Tire U Bolts
14	MB3-288	1	Rt. R. Lev. Leg Assy	43	FB3-360	2	Spare Tire U Bolt Nuts
15	FEBO2-111	4	Leg Retainer Spring	44	PUN1-2AR	2	Tire, Tube, & Rim Assy
16	PJ3-356	1	Axle	45	PUN1-5R	2	Rim
17	PUN0-13R	2	Axle Nut	46	PUN0-4	2	Tube
18	PUN0-14	2	Cotter Key	47	PUN1-3R	2	Tire
19	PUN9-7R	2	Hub	48	FB3-330	1	Floor Panel
20	PUN2-39	4	Races	49	MUN0-23	4	Rear Shackle Links
21	PUN0-10	4	Wheel Bearings	50	MUN0-16	2	U-Bolt Plate
22	PUN0-11	2	Wheel Bearing Cr. Seal	51	MEBO2-114	1	Tongue Clamp
23	PUN0-8	2	Wheel Bearing Dust Cap	52	PJ3-469	1	Trailer Coupler
24	PJ3-357	2	Leaf Spring	53	PUN0-28	6	Shackle Mount Bolt
25	SU3-322	1	Rt. Fr. Shackle Mount	54	PUN0-29	8	Shackle Mount Nut
26	SU3-321	1	Lt. Fr. Shackle Mount	55	FB3-470	1	Tongue Clip for Wiring
27	SU3-320	1	Rt. R. Shackle Mount	56	MB3-304	1	Rear Reinforcing Angle
28	SU3-319	1	Lt. R. Shackle Mount	57	PUN0-30		Lock Washer
29	PUN0-25R	6	Shackle Bolts				

ER-CARRIAGE

PARTS LIST

APACHE EAGLE CAMPING TRAILER

Item	Part No.	Req.	Description	Item	Part No.	Req.	Description
1	MB3-226	1	Right Rear Body Panel	40	MA3-327	2	Lower Cent. Bow 40"
2	MB3-224	1	Right Side Body Panel	41	MB3-297	2	Low. Bed Bow Extens.
3	MB3-223	1	Front Body Panel	42	MB3-325	2	Low. Bed Elev. Bracket
4	MB3-225	1	Left Side Body Panel	43	SB3-299	2	Lower Bed Cam Ass'y
5	MB3-227	1	Left Rear Body Panel	44	FB3-377	4	Bed Stop Bolt
6	SB3-109	1	Door & Hinges-No Handle	45	FB3-378	4	Bed Stop Nut
7	MB3-346	4	Door Hinges Only	46	SB3-310	1	Dr. Handle Assy w/LAK
8	MEBO2-117R	1	Right Rear Gusset Panel	47	MB3-263	1	Front Bed Track
9	MEBO2-117L	1	Left Rear Gusset Panel	48	MB3-264	1	Rt. Rear Bed Track
10	SB3-360	1	Complete Cabinet	49	MB3-376	1	Lt. Rear Bed Track
11	MB3-373	1	Cabinet Door Only	50	MB3-261	2	Side Rail Sl 5/8" Long
12	FB3-700	2	Cabinet Door Catch	51	MB3-271	1	Door Frame
13	FEBO2-125	2	Cabinet Handle	52	MB3-272	2	Body Trim Molding
14	MB3-375	2	Cabinet Stay Hinge Rod	53	FB3-340	37	Body Slide Snap
15	MB3-336	4	Bed Rail - Short	54	MBO9-46	1	License Plate Bracket
16	MB3-335	4	Bed Rail - Long	55	MB3-362	2	Vinyl Bed Track Cap
17	MB3-332	2	Bed Bottom Panel	56	FB3-361	1	Eagle Name Plate
18	MEBO2-146	8	Bed Reinf. Corners	57	FB3-365	2	Comb. Stop & Tail Lite
19	MB3-334	4	Bed Z Bar	58	FE19-7		Hep. Tail Lite Lens
20	MBO2-32R	10	Clips - Under Beds	59	FE3-366	2	Tail Lite Only
21	MB3-333	4	Bed Tray Slides	60	FEBO2-47R	1	Apache Name Plate
22	MB3-324	2	Now Pivot Plates	61	FB3-379	1	Floor Mat
23	MB3-298	2	Up. Bed Elev. Brackets	62	MB3-367	4	Body Corner Cap
24	MA3-296	2	Bed Bow	63	SB3-331	1	Comp. Lower Bed Ass'y
25	MA3-328	1	Upper Center Bow	64	SB3-337	1	Comp. Upper Bed Ass'y
26	FB3-462	12	Spacers	65	SB3-707	1	Road Cover Ass'y
27	SB3-313	2	Up. Stay Brace Arm Assy	66	ST3-474	1	Tent Assembly
28	FB3-463	1	Door Weatherstrip	67	ST3-560S	1	Window Flap Zip. 60"
29	FB02-124	6	Name Plate Speed Clip	68	ST3-567S	2	Window Flap Zip. 67"
30	FE3-364	1	Wiring Harness	69	ST3-556S	2	Fr. Panel Wind. P. Zip 50"
31	MB08-57	8	Bed Leg Pivot Angle	70	ST3-565S	2	Window Top Flap 65"
32	MA3-305	4	Bed Leg 74" Long	71	ST3-561D	1	Door Zipper 63"
33	MA3-307	4	Bed Leveling Leg	72	ST3-6144	1	Canopy Zipper 144"
34	SB3-308	6	Telescope Latch Assy	73	ST3-671	2	Add-A-Room Zipper 71"
35	SB3-406	2	Upper Bed Cam Ass'y	74	FEBO2-87		Lock Cylinder & Key
36	MEBO3-124R	1	Rt. Cab. Pivot Bracket	75	FB3-703		Key Only
37	MEBO2-124L	1	Lt. Cab. Pivot Bracket	76	PTE2-25R		Elastic Tie Down w/HX.
38	FB3-341	2	Body Weatherstrip	77	ST3-704		Elastic Tie Down w/Eye
39	ST3-434	2	Mattress				

BODY & TENT